

# AC100<sup>®</sup> PRO

high performance  
fast cure  
styrene free  
fire rated

Distributed by:

**Aerofast Australia Pty Ltd**

**ABN: 23 068 361 455**

**LOGAN CITY**

**8 Booran Drive, Woodridge QLD 4114**

**Tel: 07 3299 4555 Fax: 07 3299 4566**

**email: sales@aerofast.com.au**

**GOLD COAST**

**Unit 1/13 John Duncan Court**

**Varsity Lakes QLD 4227**

**Tel: 07 5593 4550 Fax: 07 5593 4549**

**email: coastsales@aerofast.com.au**

**WEB: www.aerofast.com.au**



*Powers offers the widest range of mechanical and adhesive fasteners in the market place. Powers products cover the full traditional anchoring range while specialising in innovative products that provide the architect, engineer and end user with aesthetic, high performance, labour saving fastening solutions.*

*Fast technical advice, free samples and free on site demonstrations.  
Call toll free 1800 677 872 or visit our web site [www.powers.com.au](http://www.powers.com.au)*

## Powers adhesive systems

## Support



Power-Fast® PRO  
Heavy duty  
Odourless  
Epoxy anchoring  
adhesive



Training Facility  
Melbourne



AC100e  
Standard caulking gun  
Easy to apply



In-house Product &  
Application Testing  
Service  
Melbourne



KF2  
Economical  
Easy to apply



National on Site  
Anchor Testing  
Service



Chem-Stud®  
Hammer Capsule®  
High performance  
Economical  
Versatile  
Epoxy acrylate resin



National On Site  
Service  
Powers Training  
Vehicles (PTV)

## ***Contents***

Introduction	4
Selection guide	4
Material properties	6
Performance data	7
Estimating guide	10
Installation instructions	10
Health and safety	10
Suggested specifications	10

# AC100® PRO

## Introduction



AC100®PRO is a two component, styrene free system which contains methacrylic ester as the reactive solvent. It is a fast curing adhesive specially designed for anchoring in a wide range of weather conditions. AC100®PRO is resistant to many chemicals including alkali media. The AC100®PRO Adhesive Anchor System consists of a two part adhesive cartridge, a specially designed static mixing nozzle, and a dual piston dispensing tool. The adhesive contained within the cartridge is a vinylester which can be used in a wide range of weather applications for the installation of threaded rod in solid concrete and masonry materials. It can also be used with Powers screen tubes and threaded rod in hollow masonry base materials. AC100®PRO adhesive bonds the anchor rod to the base material so no expansion forces are exerted against the walls of the hole. This makes it ideal for use in anchoring to a variety of base materials ranging from soft common brick to hard marble or granite.

Designed in a compact 385ml size, the cartridge and dispensing tool are lightweight which simplifies handling. This makes the system ideal for use in tight areas such as applications where the user must work on scaffolding. Each cartridge is formed from an engineered plastic with a specially sealed tip to provide optimum shelf life and prevent leakage during storage. If the adhesive is not completely used, the cartridge can be sealed and saved for future use. To ensure proper mixing of the adhesive components, the AC100®PRO System uses a specially designed static mixing nozzle to automatically combine the components as they are dispensed. This reduces the possibility of mixing errors.

For easy dispensing, the AC100®PRO manual tool has a dual piston design which applies even, consistent pressure to the cartridge to ensure proper dispensing of the adhesive material. The tool has a cradle style frame for easy cartridge loading and a pump style drive mechanism for fast dispensing of the AC100®PRO adhesive. The main handle assembly is manufactured from precision cast steel for long life. To further increase production, the tool incorporates a wear compensation mechanism which reduces the number of strokes required to dispense a cartridge. This specially designed mechanism also ensures consistent pumping over the life of the tool.

AC100®PRO is a fast curing, non-sag adhesive which makes it ideal for horizontal applications as well as vertical ones. Unlike other systems on the market, one formulation is used for both solid and hollow applications, reducing the chances of job site installation errors. The fast curing characteristics of the AC100®PRO formulation make it ideal for use in a broad range of weather applications.

## AC100® PRO Selection guide

### AC100®PRO Cartridges

PART NO	DESCRIPTION	QTY
AC100PRO	385ml Cartridge + 2 mixing nozzles	1

**Manual injection tools**

The CG 385 manual injection tool is designed with a pump style drive mechanism which has a high pump ratio to provide fast dispensing. The base unit and the handle assembly is manufactured from a precision steel casting for long life. A specially designed wear compensation mechanism ensures consistent pumping over the life of the tool. The tool is designed for use with the 385ml cartridge only

The Multi-PRO (CG PRO) manual injection tool is designed with a pump style drive mechanism which has a high pump ratio to provide fast dispensing. The base unit is a unique design which allows for the dispensing of different cartridge sizes consisting of different component ratios. The CG PRO will dispense the 385ml (3:1) cartridge, 380ml (10:1) cartridge and 300ml (10:1) cartridge. CG PRO is ideal for those who use the entire Powers adhesive range.

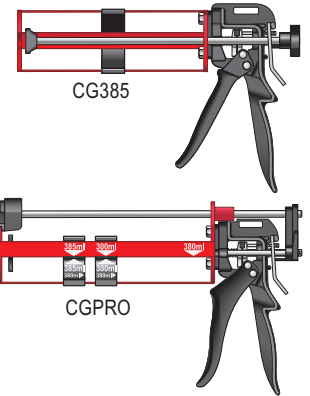

PART NO	DESCRIPTION	QTY
CG385	Dispensing gun for 385ml cartridge	1
CGPRO	Dispensing gun for all Powers adhesives	1

**Pneumatic injection tool**

The AC100@PRO Cartridge System pneumatic injection tool is designed for large jobs. The main cylinder is formed using top quality aluminum to provide a lightweight, durable tool. The dispensing trigger is designed to provide instant pressure relief from the cartridge which reduces waste.

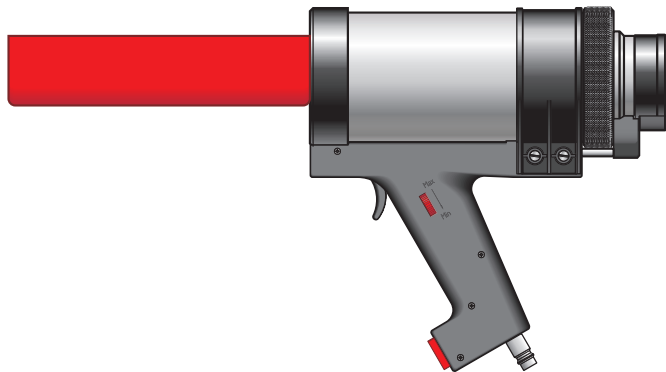

PART NO	DESCRIPTION	QTY
CGPN385	Pneumatic Dispensing gun for 385ml cartridges	1

*Maximum Operating Pressure - 110 psi  
Normal Operating Range - 80 to 100 psi  
Maximum Free Air Required - 1 CFM based on average use*

**Cartridge system nozzle**

The unique design allows one nozzle to be used with all anchor hole sizes. On small jobs, anchor holes as small as 10mm in diameter and 150mm in depth can be easily filled. For larger jobs, the AC100@PRO nozzle can be used in conjunction with the mixer nozzle extension for anchor holes larger than 18mm and depth of up to 350mm.

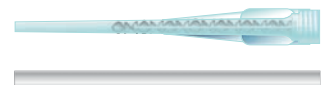

PART NO	DESCRIPTION	QTY
8482	Nozzle	10
MNEXT	Nozzle extension (200mm)	10

## AC100®PRO material properties

The AC100®PRO adhesive is a vinyl ester styrene free resin. The performance criteria for use as an anchoring system for threaded rods and reinforcing bars are described in the sections that follow.

Shelf life	18 month
Storage conditions	Store dry at 5° to 25° C.
Colour	Grey
Usable volume	385 ml

### AC100®PRO setting time

The setting times listed for the AC100®PRO adhesive vary according to the base material temperature. The working time is the maximum time during which the adhesive can be dispensed before it begins to set. The curing time is the minimum time required for the AC100®PRO adhesive to reach its published capacities.

BASE MATERIAL TEMP. (°C)	WORKING TIME (Minutes)	CURING TIME (Minutes)
5	25	120
10	15	80
20	6	45
30	4	25
35	2	20

### Effect of elevated temperature

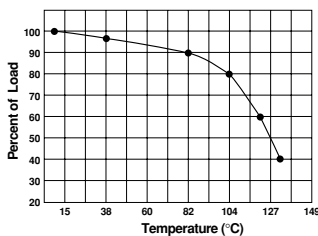

As with all adhesive anchors, the bond strength of the AC100®PRO adhesive is affected by elevated temperatures in the base material. As the temperature of the base material increases, the bond strength of the anchor will decrease. Typical performance of the AC100®PRO adhesive at elevated base material temperatures is shown below. The values are based on maintaining the concrete test samples used at a given temperature for a minimum of 24 hours before applying a test load.

### Resistance of AC100®PRO adhesive to chemicals

The resistance of the cured AC100®PRO adhesive to various chemicals was determined by laying moulded samples of the resin in the respective chemical agents. The samples were subjected to a bending strength test before and after a 12 month exposure to the chemicals. The adhesive was rated as resistant if there was no visible deterioration and less than 25% reduction in bending strength. This exposure is extreme. Under normal installation conditions, the adhesive is exposed to the chemical agents only at the surface of the concrete around the top of the anchor hole.

CHEMICAL AGENT	CONCENTRATION	RESISTANT	NON RESISTANT
Accumulator acid		●	
Acetic Acid	40		◆
Acetic acid	10	●	
Acetone	10		◆
Ammonia, aqueous solution	5	●	
Aniline	100		◆
Beer	100	●	
Benzine (kp 100-140 °C)	100	●	
Benzole	100		◆
Boric acid, aqueous solution		●	
Calcium carbonate, suspended in water	All	●	

Calcium chloride, suspended in water		●	
Calcium hydroxide, suspended in water		●	
Carbon tetrachloride	100	●	
Caustic soda solution	40		◆
Citric acid	All	●	
Chlorine	All	●	
Diesel oil	100	●	
Ethyl alcohol, aqueous solution	50		◆
Formaldehyde, aqueous solution	30	●	
Formic Acid	100		◆
Freon		●	
Fuel oil		●	
Glycol (Ethylene Glycol)		●	
Hydrogen peroxide	30		◆
Hydrochloric acid	Conc.	●	
Isopropyl alcohol	100		◆
Lactic acid		●	
Linseed oil	100	●	
Lubricating oil	100	●	
Magnesium chloride, aqueous solution	All	●	
Methanol	100		◆
Motor Oil (SAE 20 W-50)	100	●	
Nitric acid	30		◆
Nitric acid	10	●	
Oleic acid	100	●	
Perchloroethylene	100	●	
Petroleum	100	●	
Phenol, aqueous solution	8		◆
Phosphoric acid	85	●	
Potash Lye (Potassium Hydroxide, 10% and 40% solutions)		●	
Potassium carbonate, aqueous solution	All	●	
Potassium chlorite, aqueous solution	All	●	
Potassium nitrate, aqueous solution	All	●	
Premium gasoline	100	●	
Sodium carbonate, aqueous solution	All	●	
Sodium chloride, aqueous solution	All	●	
Sodium phosphate, aqueous solution	All	●	
Sodium silicate	All	●	
Sulfuric acid	70		◆
Sulfuric acid	10	●	
Tartaric acid	All	●	
Tetrachloroethylene	100	●	
Toluene			◆
Turpentine	100	●	
Trichloroethylene	100		◆

## Performance data

### Working stress design

Allowable working loads are based on the lesser of the allowable bond strength and allowable steel strength.

ANCHOR SIZE mm	DRILL SIZE mm	EMBED. DEPTH mm	TORQUE RANGE Nm	CONCRETE 32MPa	ALLOWABLE STEEL STRENGTH (kN)		
				ALLOWABLE BOND STRENGTH kN	CLASS 4.6 Zink & Gal	CLASS 8.8 Zink & Gal	316 SS A4-50
M8	10	80	10 - 20	7.0	5.9	11.7	8.1
M10	12	90	20 - 27	10.0	9.4	18.6	12.8
M12	14	110	27 - 40	14.9	13.5	27.0	18.6
M16	18	125	40 - 50	21.0	25.1	50.0	24.5
M20	24	170	80 - 150	30.8	39.2	81.2	53.9
M24	28	210	110 - 215	38.2	56.4	117.2	77.9

### Tension

**Shear**

ANCHOR SIZE mm	DRILL SIZE mm	EMBED. DEPTH mm	TORQUE RANGE Nm	CONCRETE 32MPa		ALLOWABLE STEEL STRENGTH (kN)		
				ALLOWABLE BOND STRENGTH kN	CLASS 4.6		CLASS 8.8	316 SS
					Zink & Gal	Zink & Gal	Zink & Gal	A4-50
M8	10	80	10 - 20	5.6	3.3	6.5	5.0	
M10	12	90	20 - 27	7.7	5.2	10.4	7.9	
M12	14	110	27 - 40	13.2	7.6	15.1	11.5	
M16	18	125	40 - 50	20.9	14.3	28.6	21.4	
M20	24	170	80 - 150	34.7	22.3	46.3	33.4	
M24	28	210	110 - 215	63.0	32.2	66.7	48.3	

Incorporated Safety Factors (tension and shear): Allowable bond strength (concrete)  $f_{sc}=3$   
Allowable steel strength  $f_{ss}=2.5$

**Limit state design**

Anchor design capacities are based on the lesser of the design capacity concrete and design steel capacity

**Anchor Design Tension Capacities**

ANCHOR SIZE mm	DRILL SIZE mm	EMBED. DEPTH mm	CONCRETE 32MPa		DESIGN STEEL CAPACITY (kN)		
			DESIGN CAPACITY $\phi N_A$ (kN)	CLASS 4.6		CLASS 8.8	316 SS
				$\phi N_{tf}$ (kN)	$\phi N_{tf}$ (kN)	$\phi N_{tf}$ (kN)	A4-50 $\phi N_{tf}$ (kN)
M8	10	80	12.6	11.7	23.4	16.2	
M10	12	90	18.2	18.4	37.1	25.6	
M12	14	110	26.5	26.9	53.9	37.2	
M16	18	125	37.9	50.2	100.0	69.0	
M20	24	170	55.5	78.4	162.4	107.8	
M24	28	210	68.7	112.8	234.4	155.8	

**Anchor Design Shear Capacities**

ANCHOR SIZE mm	DRILL SIZE mm	EMBED. DEPTH mm	CONCRETE 32MPa		DESIGN STEEL CAPACITY (kN)		
			DESIGN CAPACITY $\phi V_A$ (kN)	CLASS 4.6		CLASS 8.8	316 SS
				$\phi V_{Af}$ (kN)	$\phi V_{Af}$ (kN)	$\phi V_{Af}$ (kN)	A4-50 $\phi V_{Af}$ (kN)
M8	10	80	10.1	6.5	13.0	10.1	
M10	12	90	13.9	10.4	20.8	15.9	
M12	14	110	23.8	15.1	30.2	23.1	
M16	18	125	37.6	28.6	57.1	42.8	
M20	24	170	62.5	44.6	92.6	66.8	
M24	28	210	113.4	64.3	133.4	96.6	

**Design for strength limit state**

Design is based on the lesser of the concrete and steel capacities.

$$\begin{aligned}
 N^* &\leq \phi N_{A,tf} && \text{Tension} \\
 V^* &\leq \phi V_{A,f} && \text{Shear} \\
 (N^*/\phi N_{A,tf})^{5/3} + (V^*/\phi V_{A,f})^{5/3} &\leq 1 && \text{Combined loading}
 \end{aligned}$$

Where:

- $N^*$  = Design tension force (kN)
- $V^*$  = Design shear force (kN)
- $\phi N_{A,tf}$  = Anchor design tension capacity (kN)
- $\phi V_{Af}$  = Anchor design shear capacity (kN)
- Concrete:
  - $N_A$  = Characteristic ultimate tension load capacity (kN)
  - $V_A$  = Characteristic ultimate shear load capacity (kN)
  - $\phi$  = 0.6 [Strength reduction factor]– tension and shear
- Steel:
  - $N_{tf}$  = Nominal tension capacity of steel (kN)
  - $V_f$  = Nominal shear capacity of steel (kN)
  - $\phi$  = 0.8 [Capacity factor – tension and shear]

### Reinforcing bar limit state design data

BAR Ø mm	DRILL Ø mm	ANCHOR DESIGN TENSION CAPACITIES (kN)												DEVELOPMENT LENGTH L <sub>sy,t</sub> mm			
		150	180	210	240	270	350	400	500	600	700	800	900		1000	1100	1200
N10	12	28.8	34.6	<b>39.3</b>	<b>39.3</b>												204
N12	15		43.3	50.5	<b>56.5</b>	<b>56.5</b>											235
N16	20			67.3	76.9	86.5	<b>100.5</b>	<b>100.5</b>									314
N20	25				85.6	96.3	124.8	142.6	<b>157.0</b>	<b>157.0</b>							440
N24	30						134.6	153.8	192.3	<b>226.0</b>	<b>226.0</b>						588
N28	35							179.4	224.3	269.2	<b>308.0</b>	<b>308.0</b>					687
N32	40								256.4	307.6	358.9	<b>402.0</b>	<b>402.0</b>				784
N36	44								282.0	338.4	394.8	451.2	507.6	<b>510.0</b>	<b>510.0</b>		904
N40	50								320.4	384.5	448.6	512.7	576.8	<b>628.5</b>	<b>628.5</b>	<b>628.5</b>	980
INSTALLED LENGTH L <sub>inst</sub>		150	180	210	240	270	350	400	500	600	700	800	900	1000	1100	1200	mm

#### Notes:

- 1 Capacities in **bold italic** indicate rebar development strength
- 2 Capacities incorporate a strength reduction factor  $\phi=0.6$ , in accordance with AS3600-2001
- 3  $f'_c=32$ MPa minimum
- 4 Capacities are based on Grade 500N rebar, in accordance with AS/NZS 4671:2001

### Splicing of reinforcement

Design requirements for the splicing of reinforcement shall be in accordance with AS 3600-2001, clause 13.2 (Splicing of reinforcement).

## Fixing systems for brickwork – (WA)

### Plastic sieve (AC100PRO, AC100e, KF2)

A range of sieves designed to support adhesive during the curing process, preventing costly waste due to loss of adhesive in base material cavities. For applications in hollow base materials such as brick, block and hollow core concrete. The Powers range of plastic sieves provide easy anchoring in any type of hollow base material

PART NO	DESCRIPTION	Drill Ø mm	Hole depth mm	QTY
PSM850	Sieve for M8 studs & 12mm hole	12	50	10
PSM101285	Sieve for M10 or M12 studs & 15mm hole	15	85	10
PSM1012130	Sieve for M10 or M12 studs & 15mm hole	15	130	10
PSM1685	Sieve for M16 studs & 20mm hole	20	85	10

### Allowable working loads using AC100® PRO

Tensile and shear strength (kN)  
Brick dimensions:  
305 x 90 x 162mm

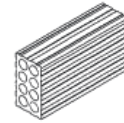
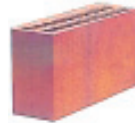
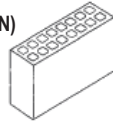

SUD SIZE mm	METRO BRICK	MIDLAND	ARMACLAY	MIDLAND
M8	2.3	2.3	2.3	2.3
M10	3.0	3.0	2.8	2.5
M12	3.0	3.0	2.8	2.5
M16	3.0	3.0	3.0	3.0

**SPECIFICATION EXAMPLE:** M8 x 75\* threaded rod used in conjunction with Powers AC100 PRO injection system and plastic sieve Part No PSM850. Installation in accordance with Powers Fasteners installation instructions for hollow base material.

\*To calculate length of rod, combine **SIEVE LENGTH + 16mm + FIXTURE THICKNESS**

## Fire resistance

Fire resistance of AC100®PRO injection system in combination with anchor rods of sizes M8 to M20 in galvanised steel. Fire resistance relates to maximum tension loads for various durations of time.

ANCHOR SIZE	FIRE RESISTANCE TIME			
	Max 30 min Tension load (kN)	Max 60 min Tension load (kN)	Max 90 min Tension load (kN)	Max 120 min Tension load (kN)
M8	≤1,90	≤0,85	≤0,55	≤0,40
M10	≤4,50	≤2,10	≤1,35	≤1,00
M12	≤6,00	≤3,00	≤2,00	≤1,50
M16	≤11,00	≤6,60	≤4,90	≤4,00
M20	≤16,00	≤9,00	≤6,40	≤5,00

NOTE: For further information please contact Powers Fasteners Technical Department

## Estimating guide

Refer to Powers website, [www.powers.com.au](http://www.powers.com.au), technical literature section and request the latest **Powers Adhesive Volume Calculator**

## Installation instructions

For installation instruction see pages 17 to 19 in the Design Manual

## Health and safety

Material safety data sheet available on request. (Ref. Chemwatch report 4726-10 and 4726-11)

## Suggested specification

AC100®PRO Injection System  
Stud/Re-Bar Size + Length  
Drill Size (mm)  
Embedment Depth (mm)

**NOTES:**



**VIC HQ:**  
TELEPHONE: **03-8787 5888**  
FACSIMILE: 03-8787 5899

**NSW:**  
TELEPHONE: **02-9748 7766**  
FACSIMILE: 02-9648 5977

**SA:**  
TELEPHONE: **08-8346 5611**  
FACSIMILE: 08-8346 5711

**QLD:**  
TELEPHONE: **07-3216 7122**  
FACSIMILE: 07-3216 7216

**FAR NORTH QLD:**  
TELEPHONE: **0439 083 646**  
FACSIMILE: 07-4036 4166

**WA :**  
TELEPHONE: **08-9209 1211**  
FACSIMILE: 08-9209 1055

**NZ:**  
TELEPHONE: **64-9415 2425**  
FACSIMILE: 64-9415 2627

**Distributor:**

